

High Efficiency Coherent Control of Light with Multi-pass Acousto-Optic Modulation



Yuxiang Zhao¹, Jianguong Hu¹, Ruochen Gao², Ruijuan Liu, Yudi Ma¹, Saijun Wu^{*1}

¹State Key Laboratory of Surface Physics and Department of Physics, Fudan University, Shanghai, 200433, People's Republic of China

²Department of Physics, Tsinghua University, Beijing, 100084, People's Republic of China

Motivation

From laser cooling to light-pulse atom interferometry, precise control of light-atom interaction requires precise modulation of optical waveforms in time. To this end, Acousto-Optic Modulation (AOM) is uniquely powerful for achieving high speed, high contrast optical control. However, based on two-mode Bragg diffraction, traditional AOM is limited in bandwidth and the diffraction efficiency is prone to high-order and off-resonant perturbations. The inefficient and slow AOM leaves a general technical gap for high-speed, high fidelity, coherent control of light [1].

This work

Composite AOM schemes [2] show exceptional performance of coherent laser beam control. A natural step further is to enhance the performance with an N-AOM network (e.g. with $N > 5$). Here we investigate the possibility of composite diffraction by multi-passing single AOMs for resource-efficiency and compactness. Two basic double-pass types, referred to as a Sagnac and a Michelson configurations respectively, are studied in detail with which we demonstrate high-contrast "on-demand" and "synchronized" pulse routing respectively. We also demonstrate efficient double-diffractions for optical multiple-delay generation, by picking up and controlling optical pulses in a single-mode optical delay loop. The coherent splitting of nanosecond pulses may be useful for quantum optical applications.

Sagnac Configuration

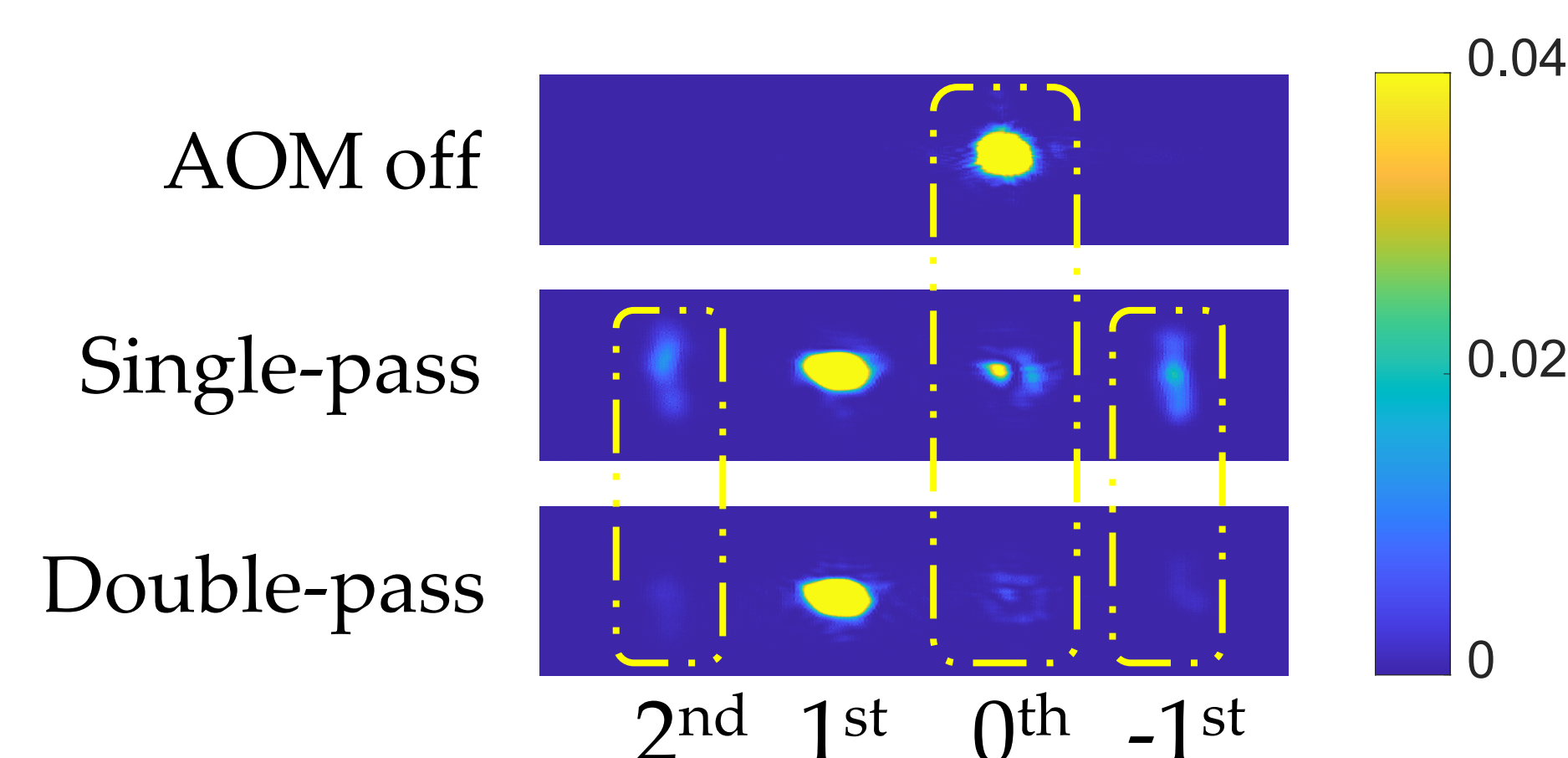
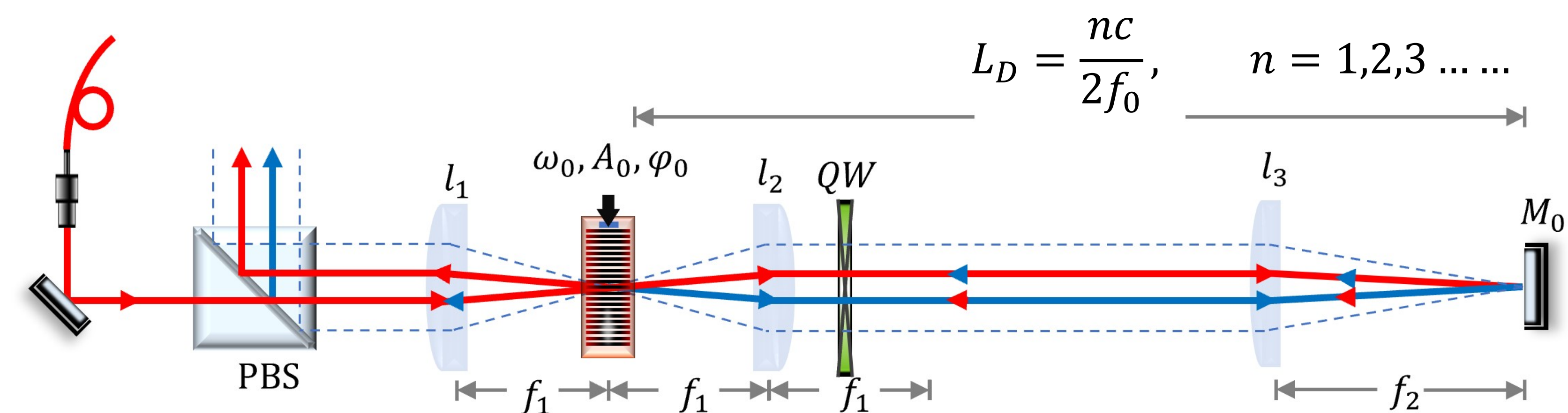

- Low RF power consumption (~25% of regular power).
- Excellent diffraction efficiency (> 97%)
- Aligned at 200MHz RF driving frequency, >90% efficiency is achieved with 40MHz bandwidth (+1 order) and 30 MHz (-1 order) respectively.
- Efficient suppression of the 0th order (20 dB) supports optical routing on demand with ~10 MHz bandwidth.

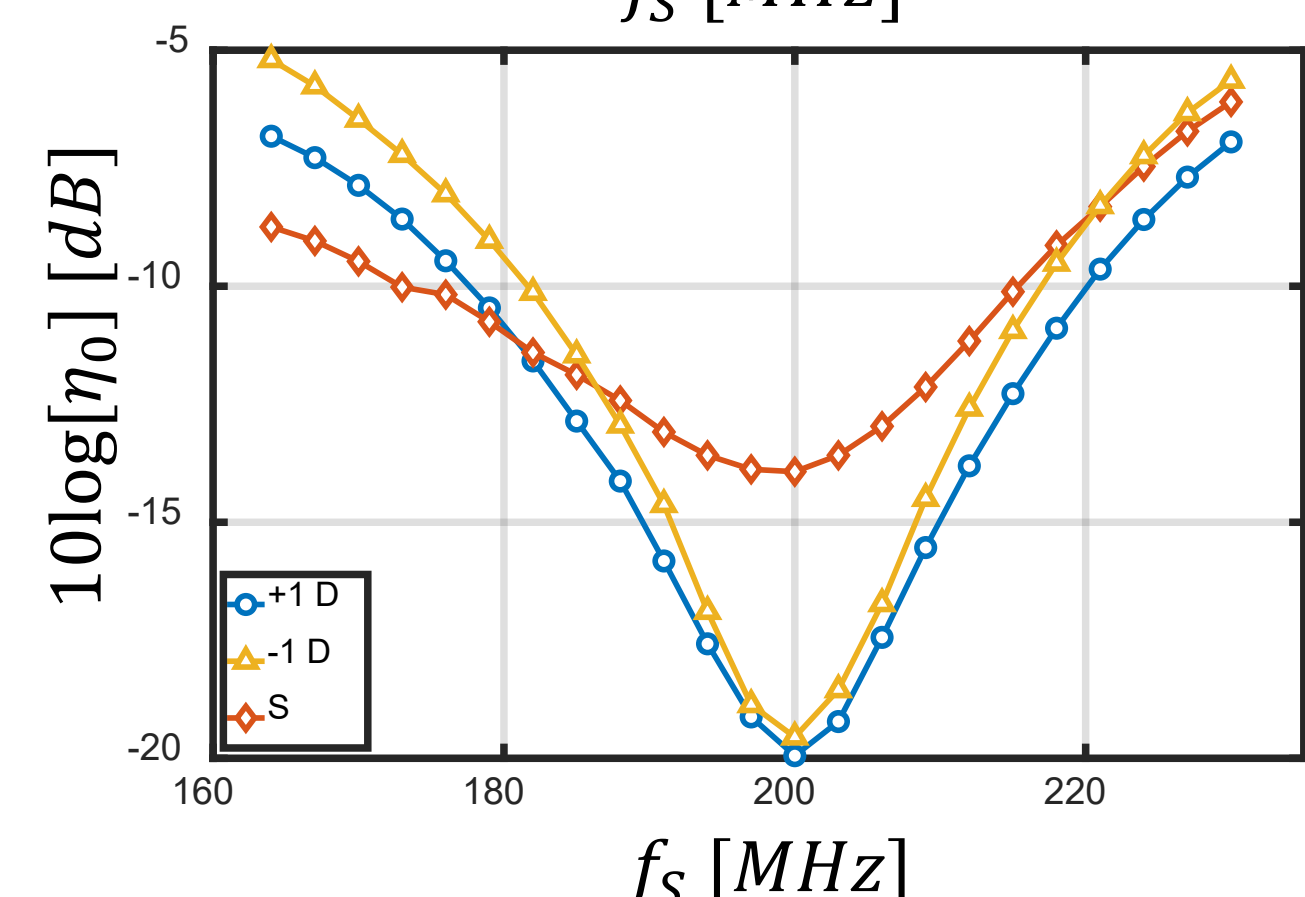
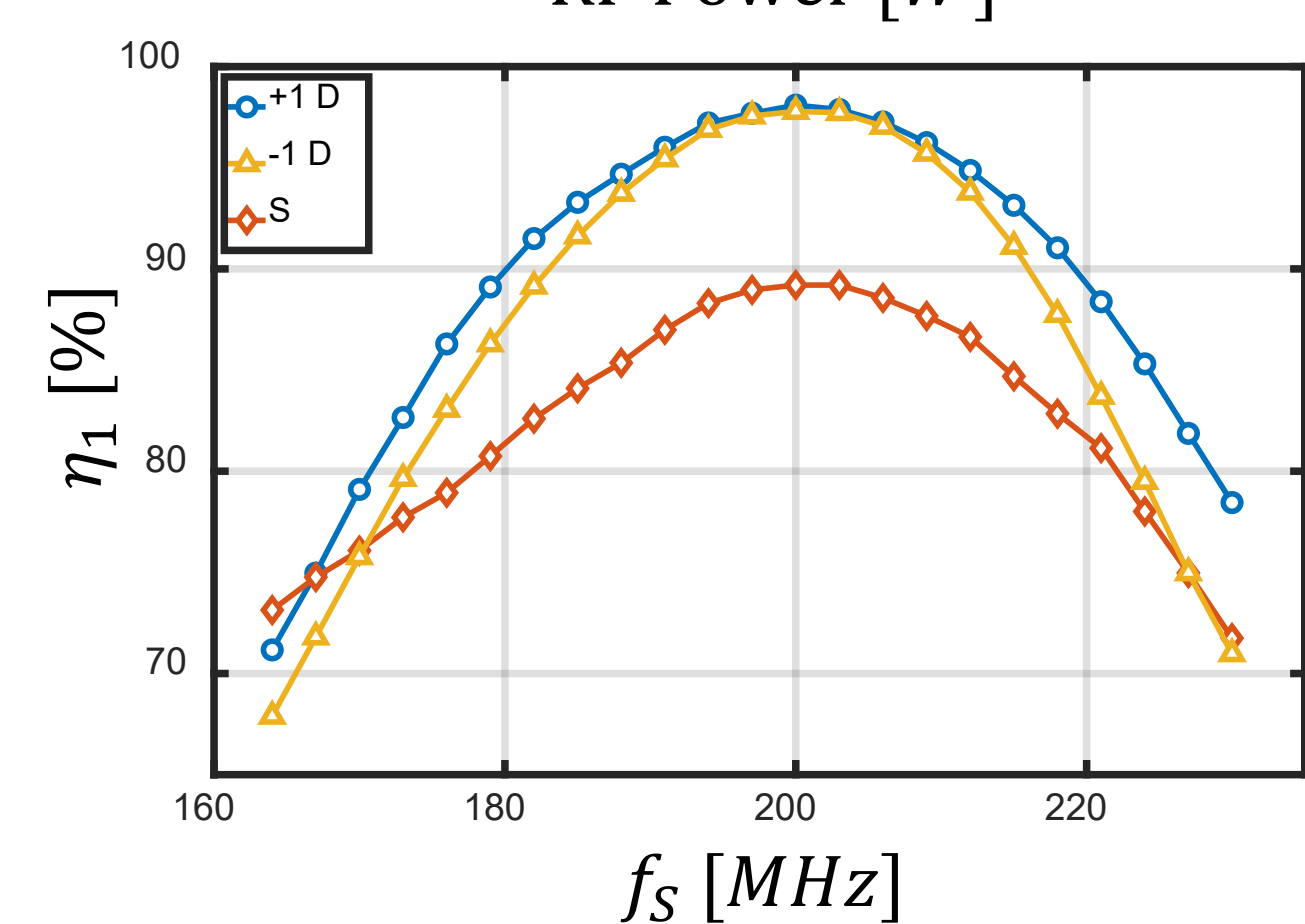
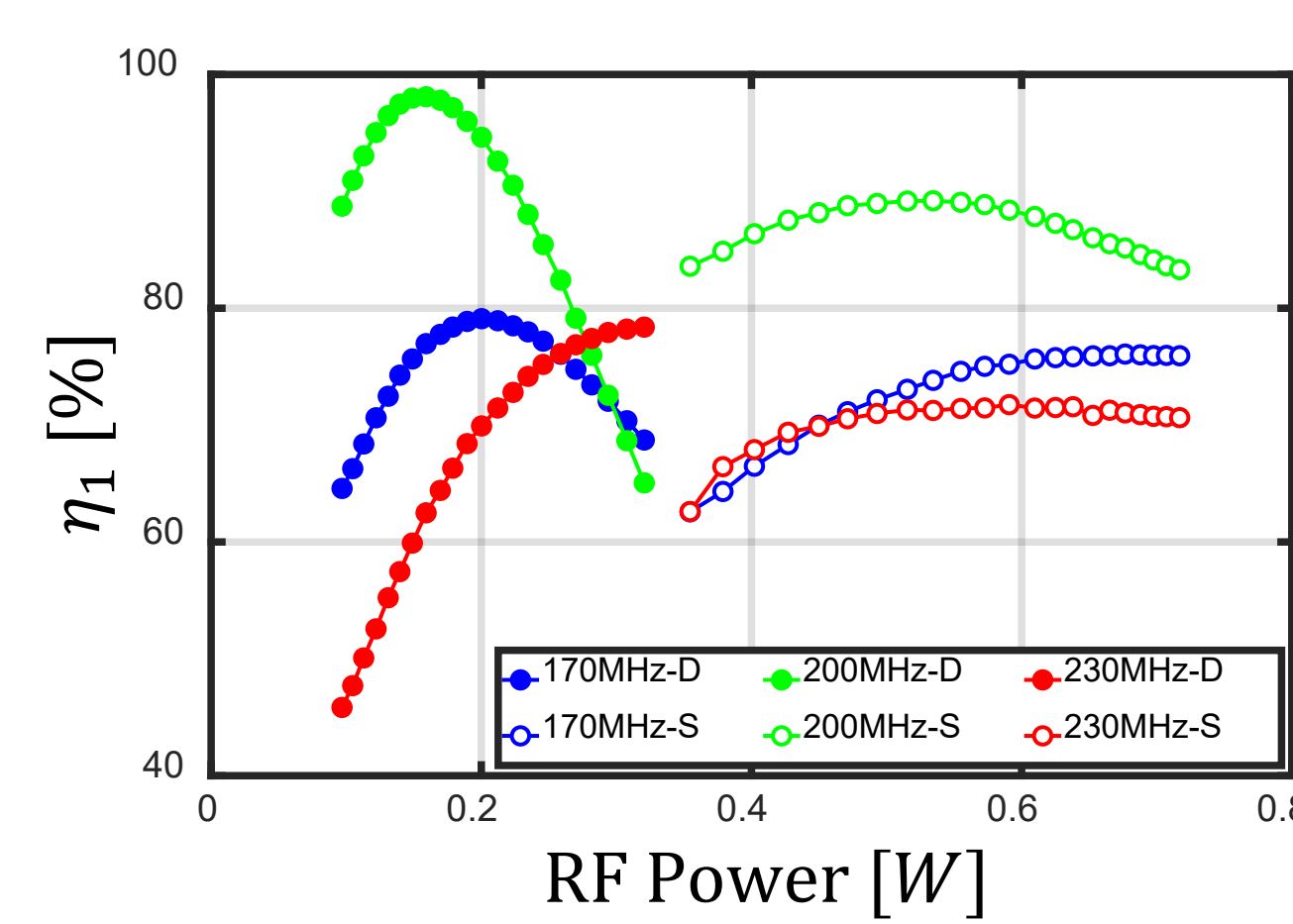

Michelson Configuration

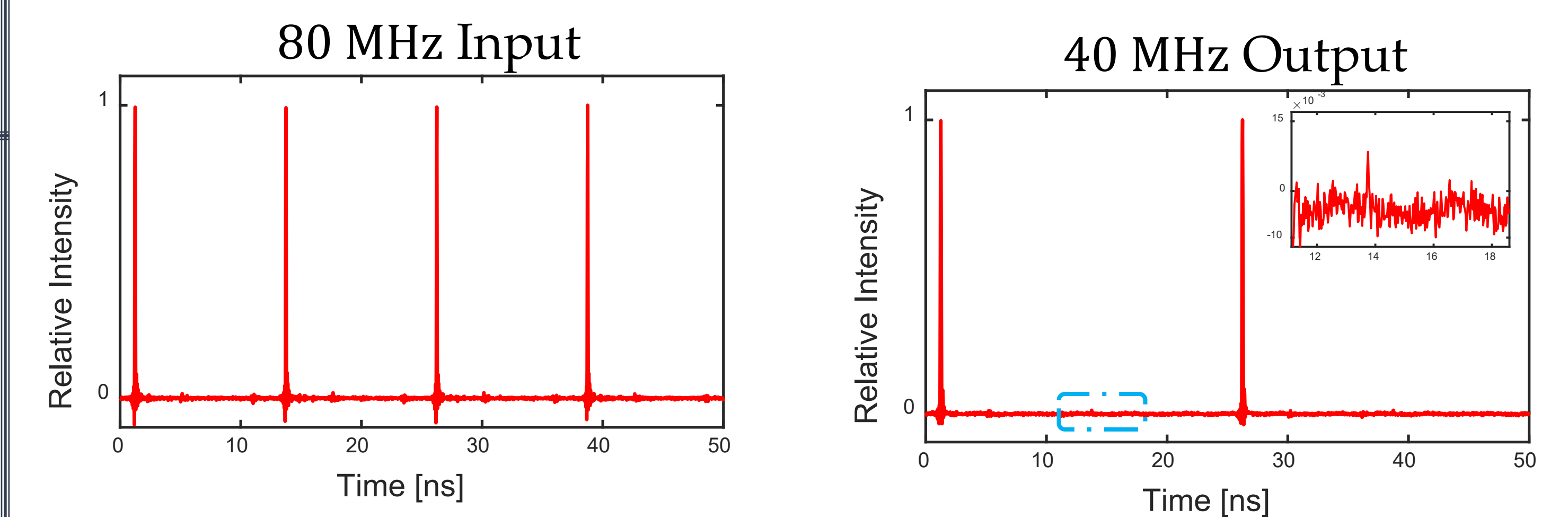
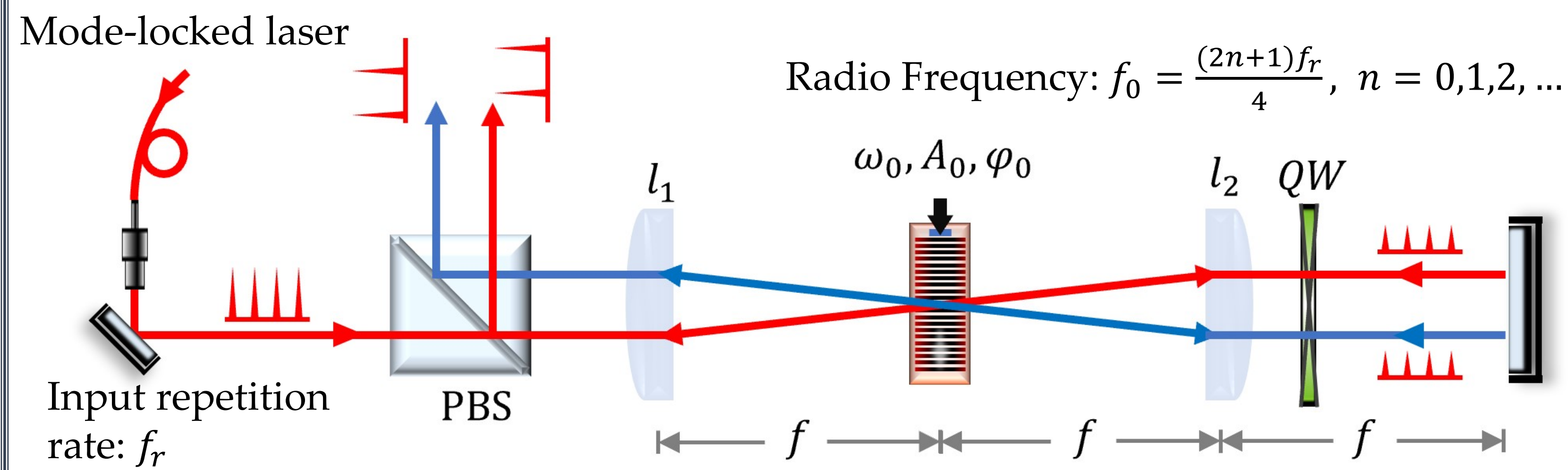

- In direct analogue to ref. [1]
- Toward compact, synchronized pulse router at GHz-rates.

Nanosecond optical multi-delay generation

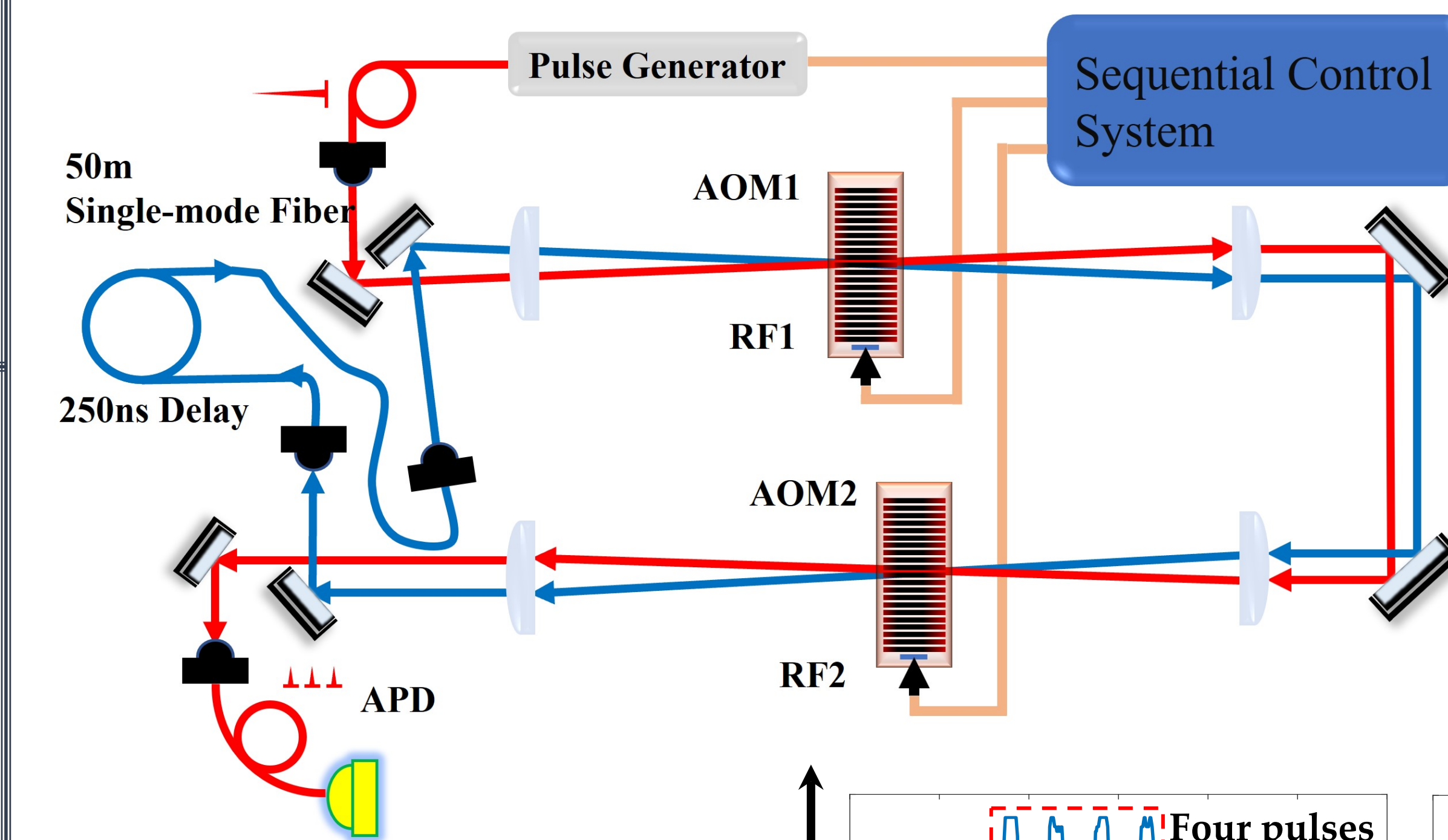

- The double-AOM drives almost all of the incoming pulse into the fiber-delayed loop (blue line), with 25% insertion loss (mainly limited by fiber loss), to be picked up on demand later.

- Multi-delay generation
- Multi-round delay time adjustment.
- Pulse intensity adjustment.

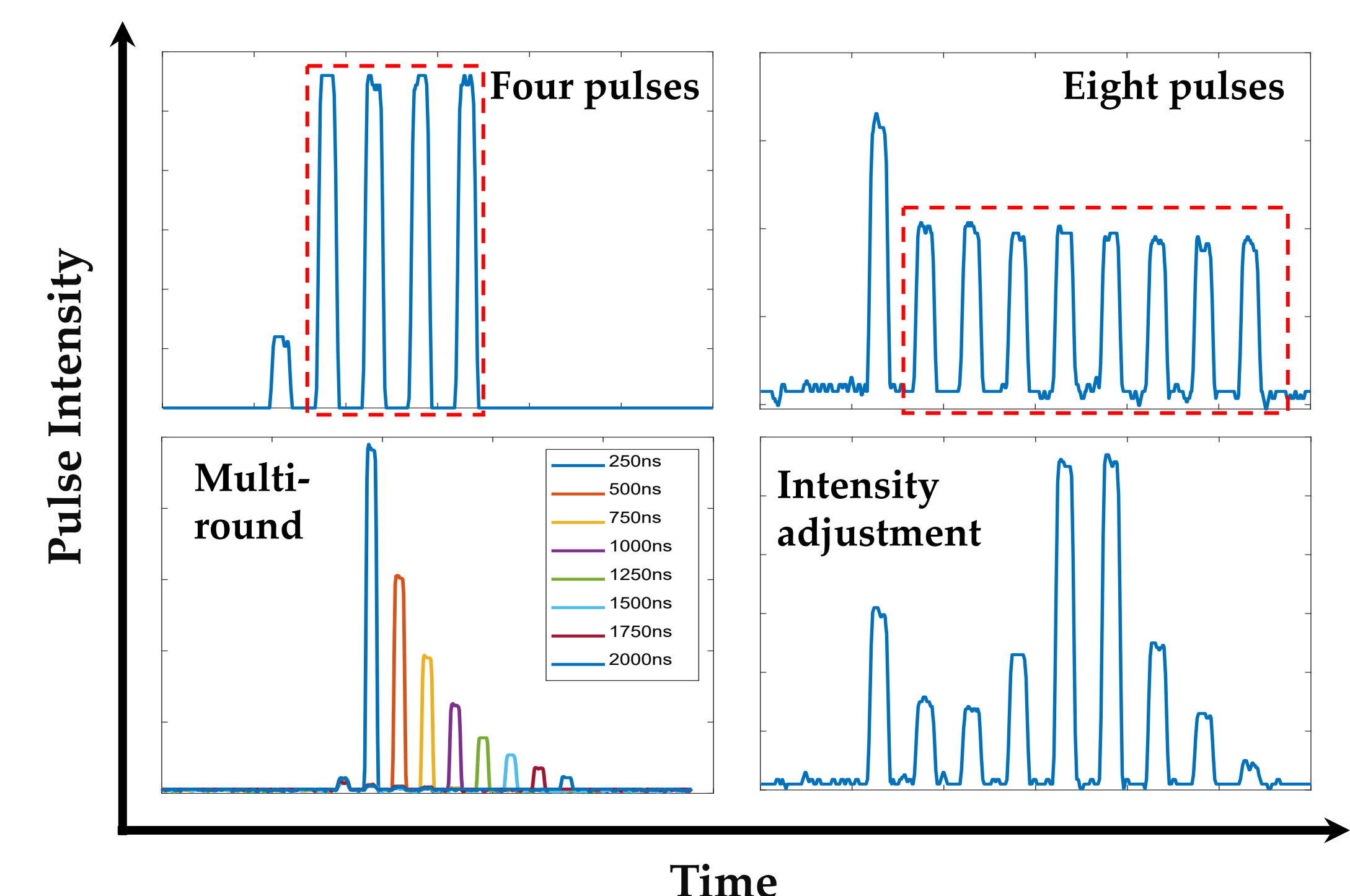

Summary

- Novel double-pass AOM for high contrast, coherent optical routing.
- MHz-level on-demanding and ~GHz-level synchronized routing.
- High efficiency optical multi-delay generation for quantum optics.

Outlook

- Multiple sideband generation. More sophisticated composite AOM network [2]

[1] C. E. Rogers and P. L. Gould, Opt. Express, 24, 2596 (2016).

[2] R. Liu, Y. Ma, et al, Opt. Express 30(15), 27780-27793 (2022) (Poster #236)

Wanted

We are hiring! Please visit our group website (ultracontrol.fudan.edu.cn) for an introduction to various projects. To discuss studentship and job opportunities, or just for visiting, please contact saijunwu@fudan.edu.cn

